

McGraw-Hill Ryerson

**BC Science
CONNECTIONS**

A large, light purple number '8' is positioned to the right of the main title text, partially overlapping the word 'CONNECTIONS'.

BC Science Connections 8

UNIT 3

Energy can be transferred as both a particle and a wave

TOPIC 3.4

**How does light
behave when it is
reflected?**



Topic 3.4: How does light behave when it is reflected?

- Light is reflected in predictable patterns.
 - Light reflected by different types of mirrors behave in unique ways
 - Example: funhouse mirrors can form misshapen images



Concept 1: Light is reflected in predictable patterns.

- Light rays follow a predictable path, no matter what surface they reflect from.
- **Laws of reflection:** three laws that describe the predictable path light follows when it strikes a reflective surface

Laws of Reflection: Ray Diagram Components

Ray diagrams can help you understand the laws of reflection.

- **Incident ray:** the light ray travelling toward the reflecting surface
- **Reflected ray:** the light ray that has bounced off a reflecting surface
- **Normal:** the line perpendicular to a surface, such as a mirror

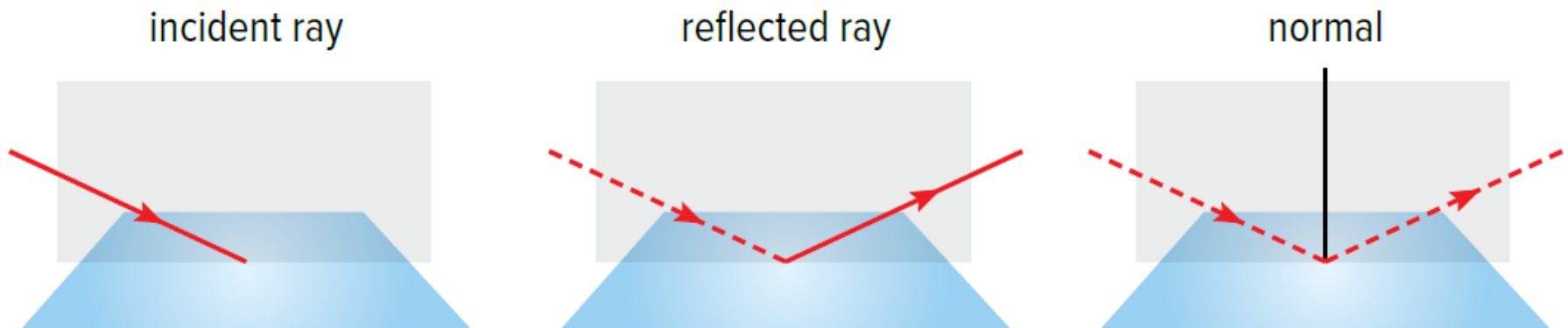

Laws of Reflection: Ray Diagram Components

- **Angle of incidence (i):** the angle between the incident ray and the normal
- **Angle of reflection (r):** the angle between the reflected ray and the normal

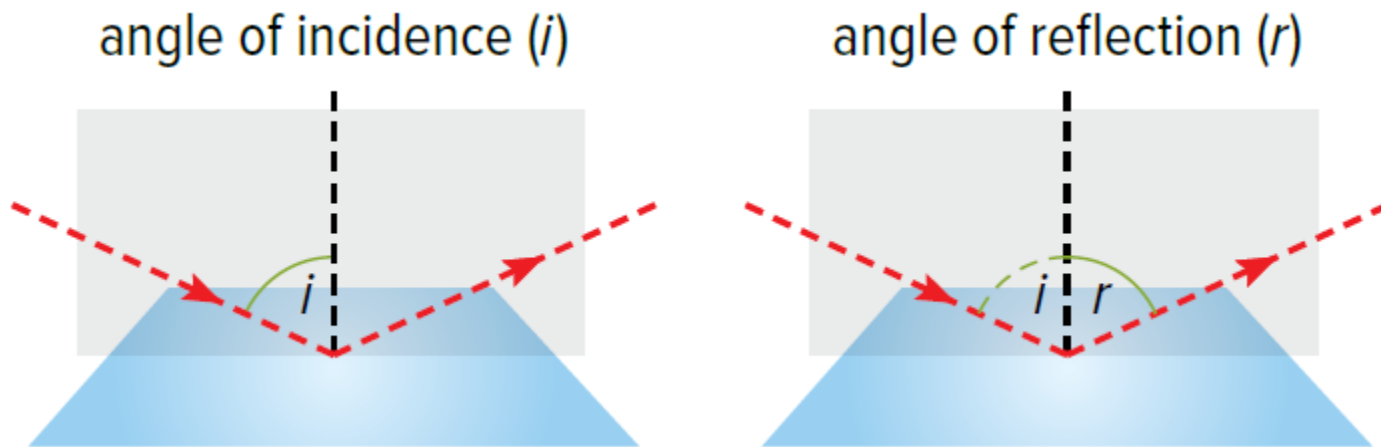

Laws of Reflection

- The angle of reflection (r) is equal to the angle of incidence (i).
- The reflected ray and the incident ray are on opposite sides of the normal.
- The incident ray, the normal, and the reflected ray lie on the same plane (flat surface).

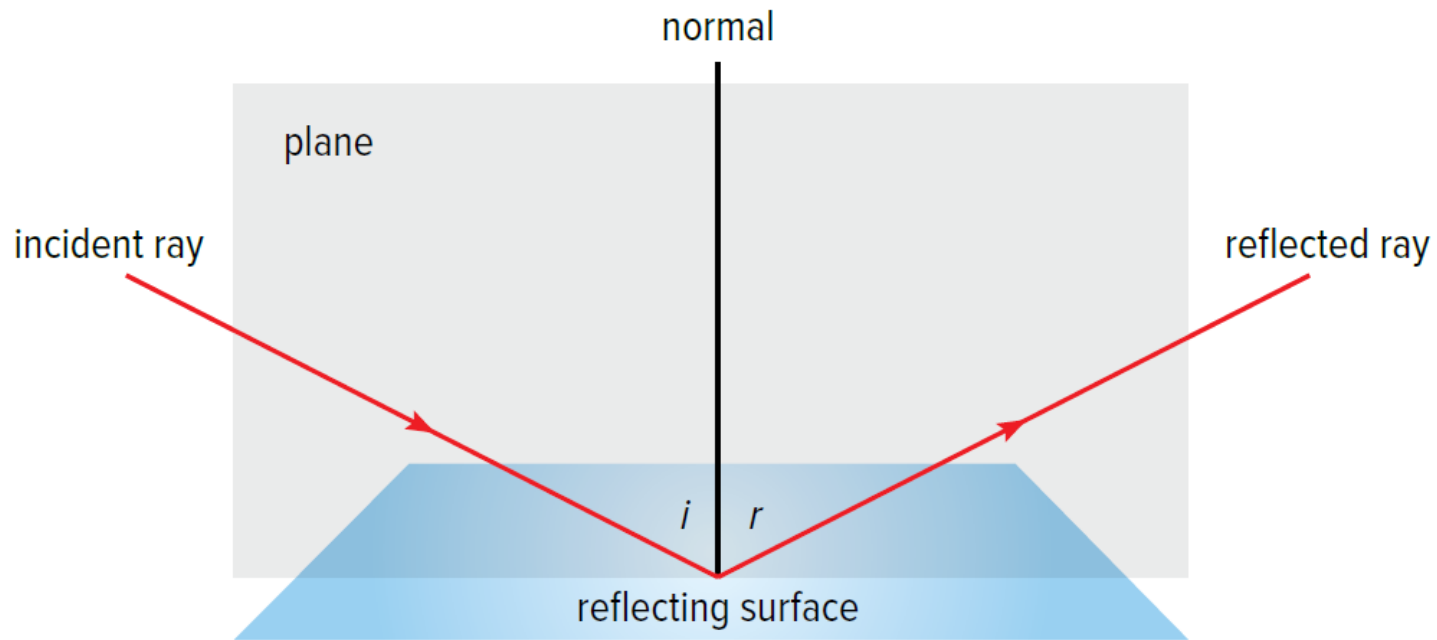

Laws of Reflection: Summary Diagram

Figure 3.24: All light rays obey the laws of reflection, as shown here.

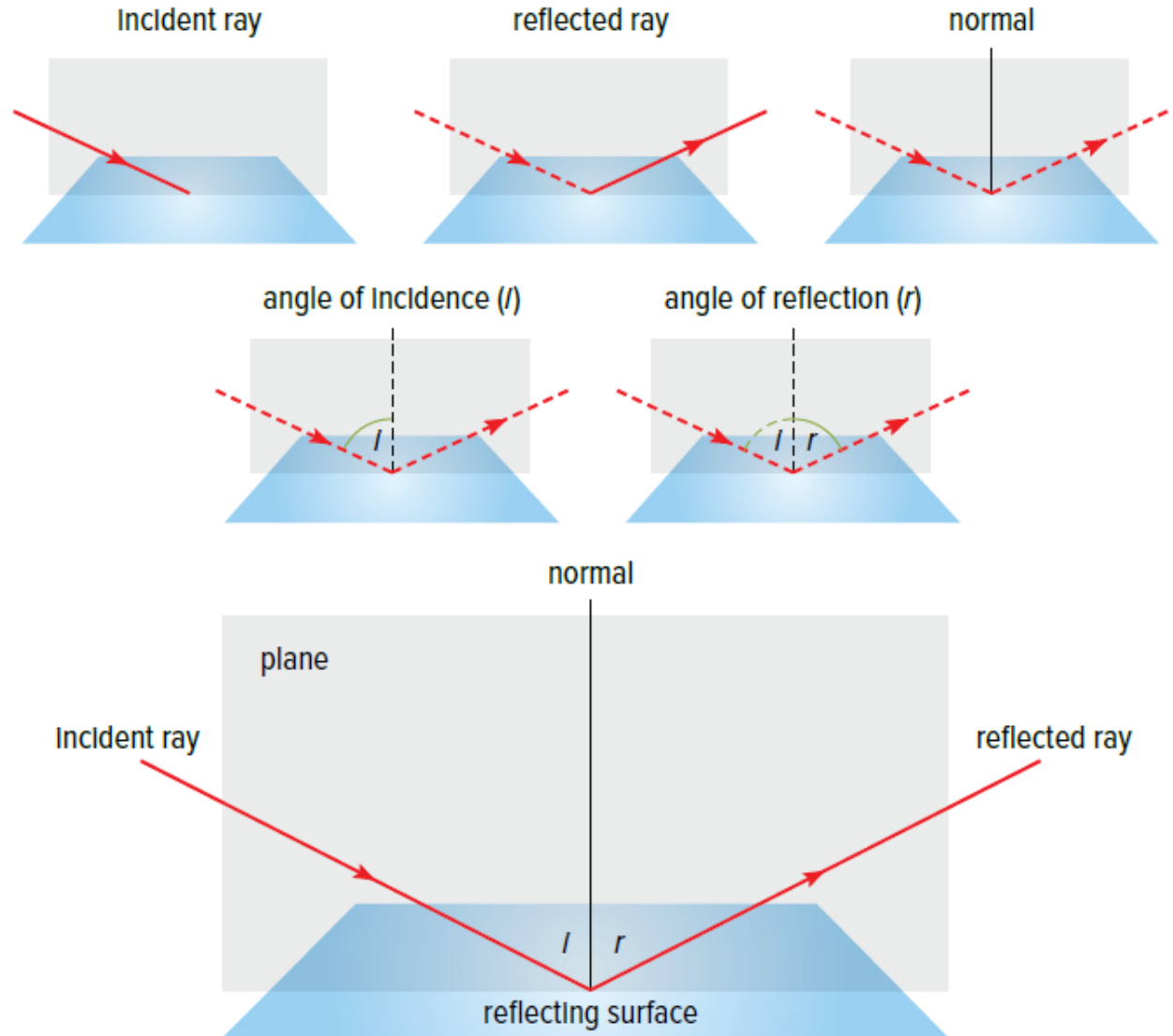

Visualizing the Laws of Reflection

A game of pool can help you visualize the laws of reflection.

- **(A)** If a shot is made head-on, the ball will bounce straight back in the opposite direction
- **(B)** If a shot is made at an angle, the ball will also bounce off at the same angle, but in the opposite direction

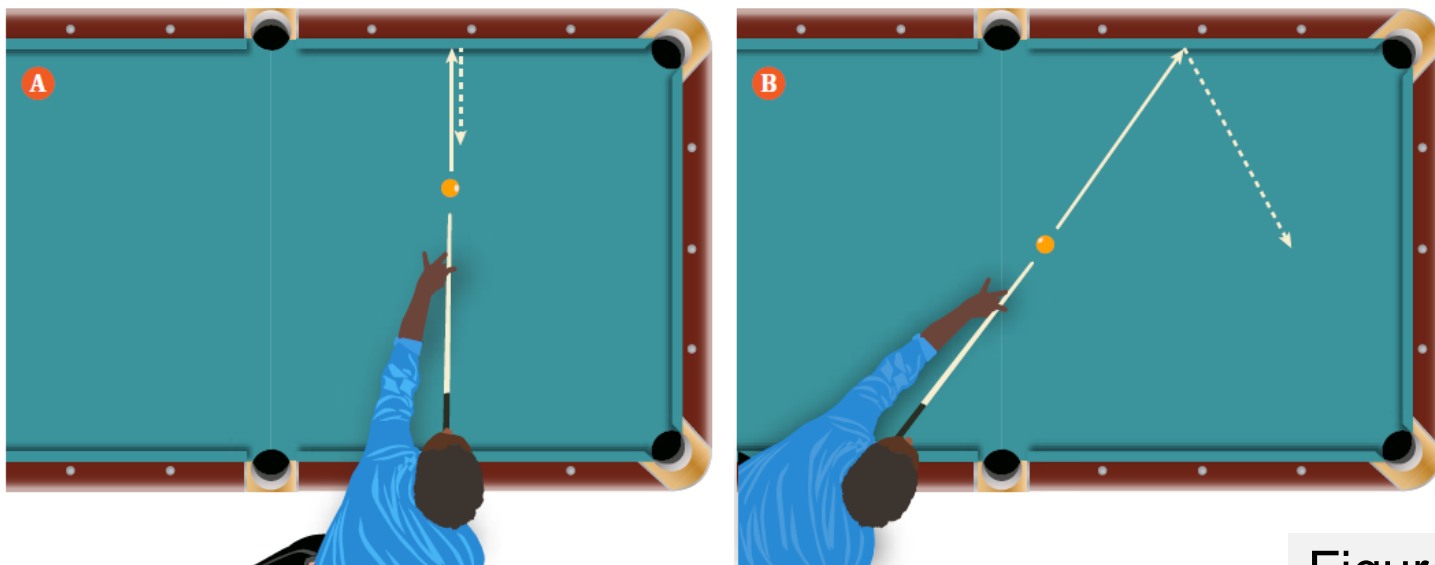
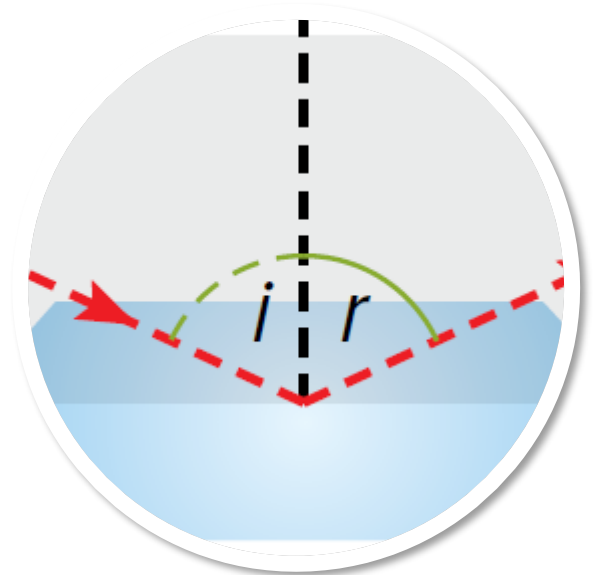

Figure 3.25

Discussion Questions

- What do the angle of reflection and the angle of incidence have in common? Consider how they are measured and how they compare to one another.
- Why does an expert billiards (pool) player need to understand the laws of reflection to make an accurate shot?



Concept 2: Light reflected by a plane mirror produces an image that is nearly identical to the object.

- **Plane mirror:** an extremely smooth, flat reflective surface
 - Some sources are artificial (cell phones, light bulbs)
 - Some sources are living organisms (humans)



Figure 3.26: Reflection in a plane mirror.

How an image forms in a plane mirror

- When light shines on an object (the tomato), it reflects on all points of the object in all directions.

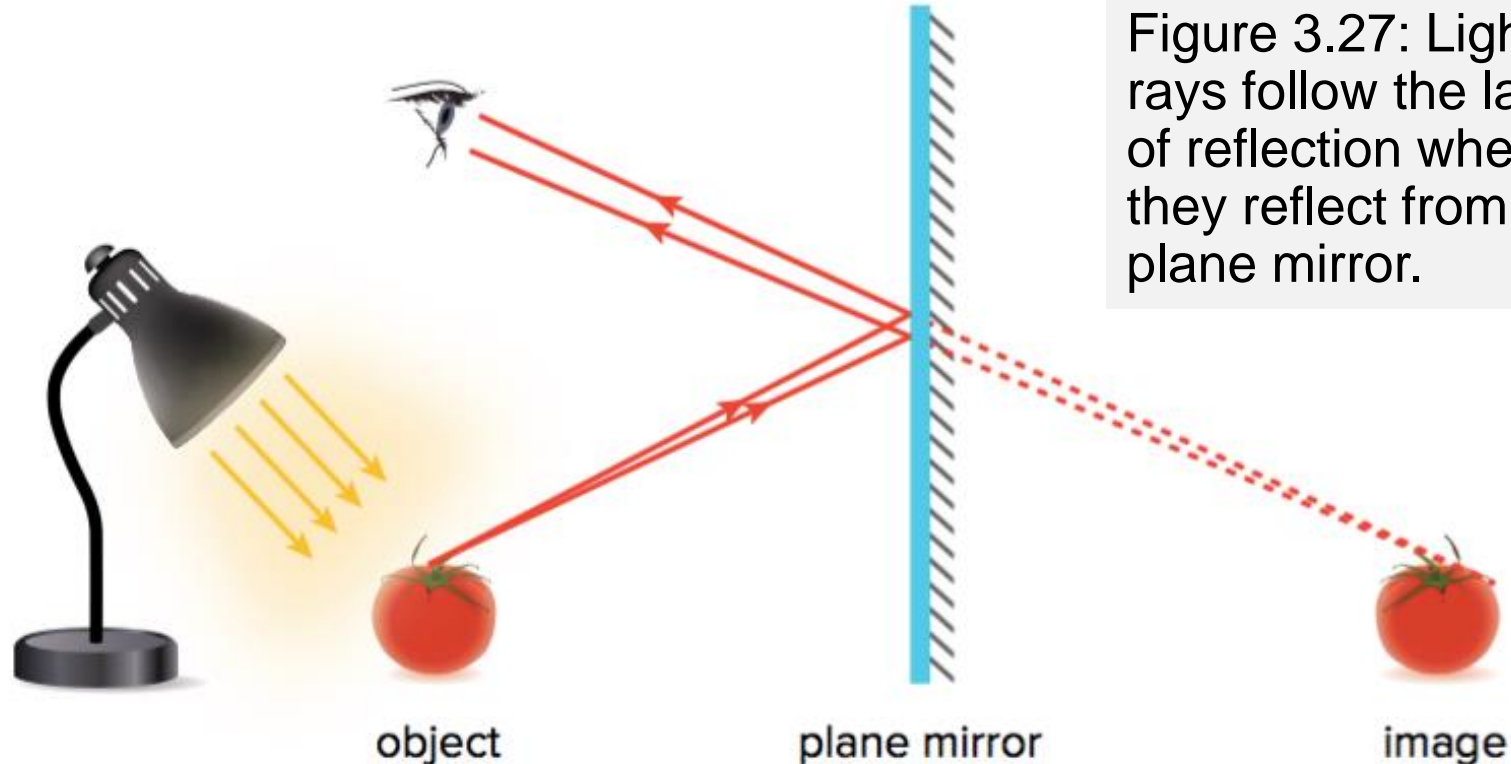
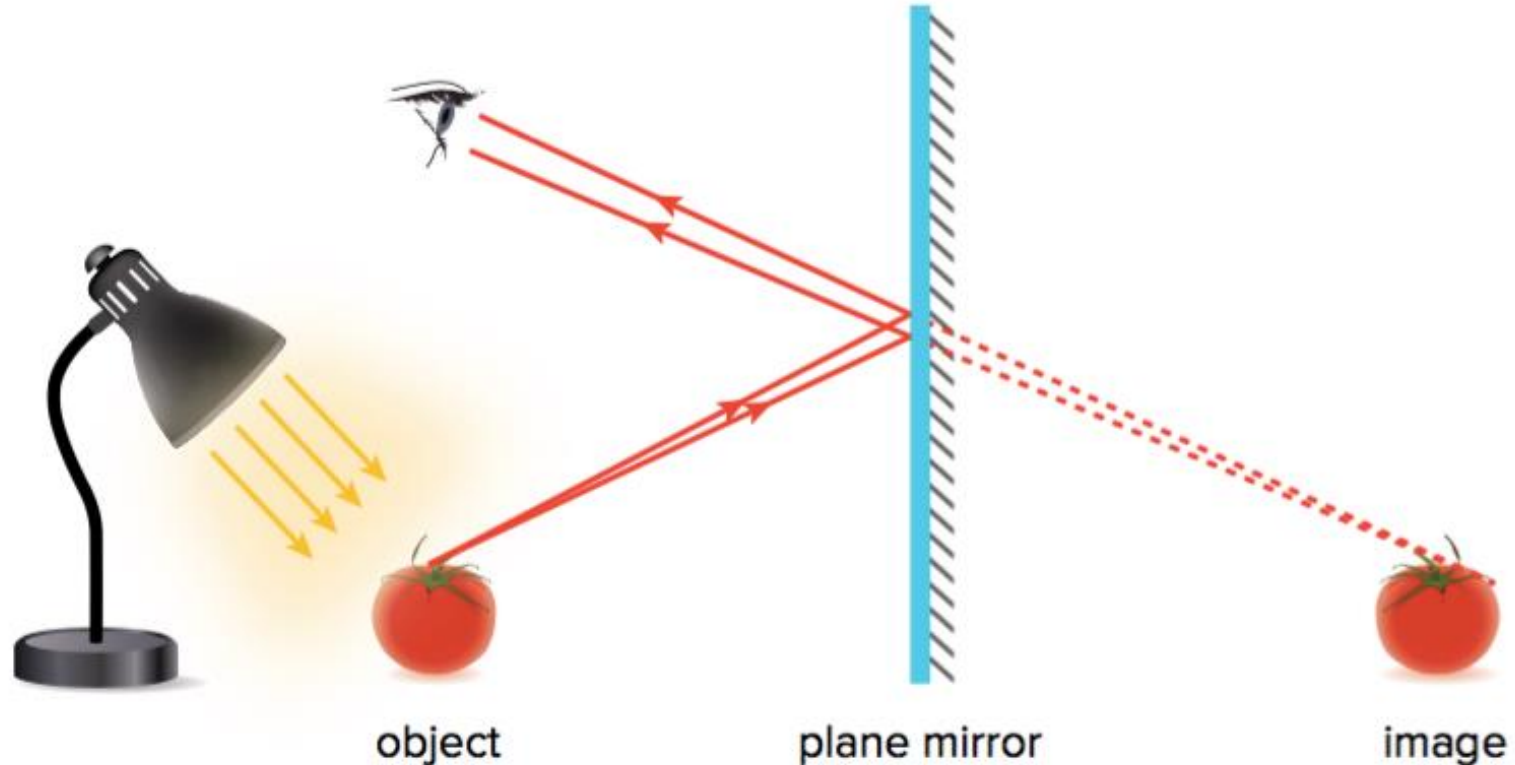

Figure 3.27: Light rays follow the laws of reflection when they reflect from a plane mirror.

How an image forms in a plane mirror

- When these reflected rays reach the plane mirror, they follow the laws of reflection and reflect backwards.



How an image forms in a plane mirror

- Some rays reach your eyes if you are looking at the mirror.
 - They carry the same pattern of light to the eye that was reflected off the object.

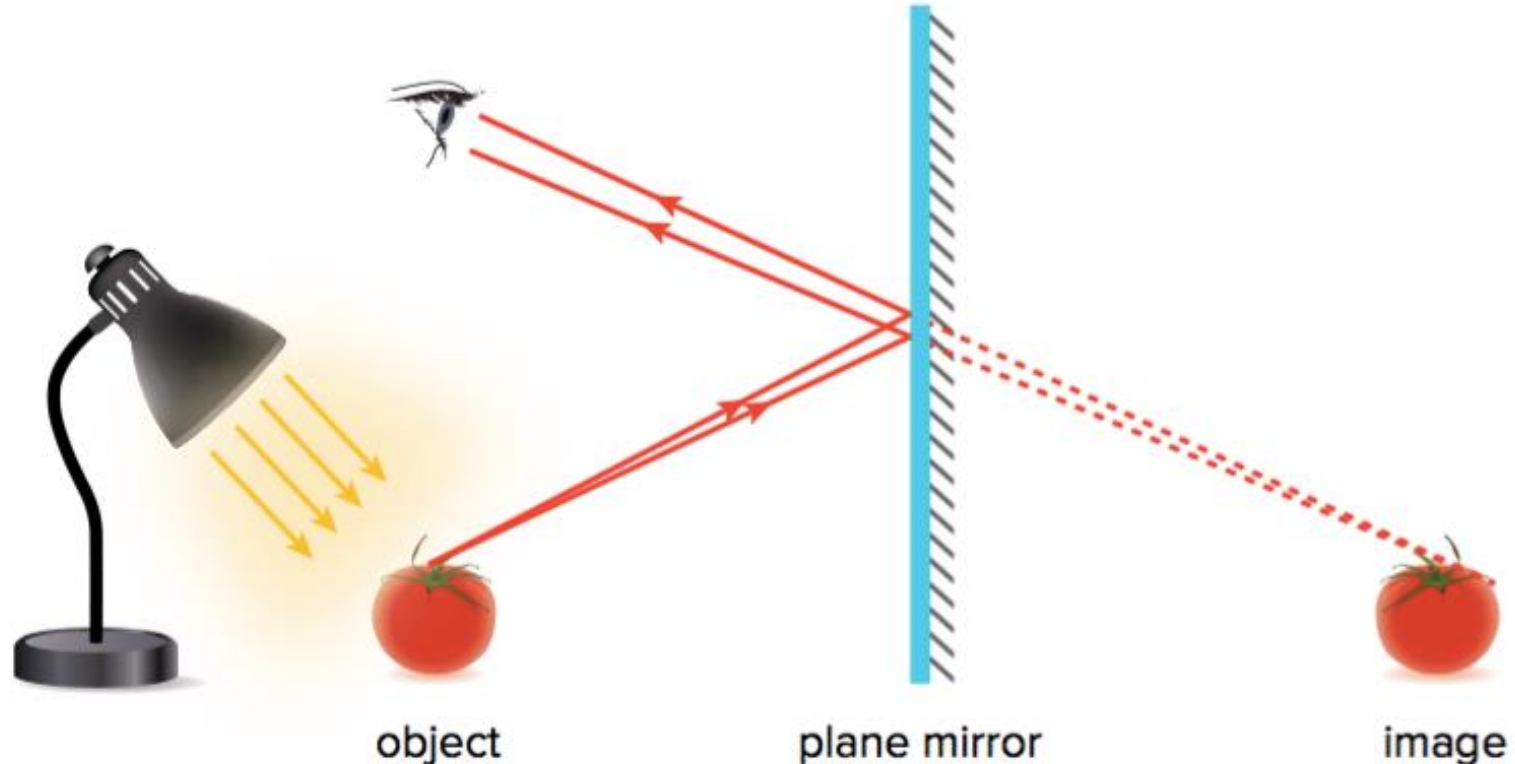

How an image forms in a plane mirror

- Your brain assumes light travels in a straight line and thinks the image is behind the mirror.

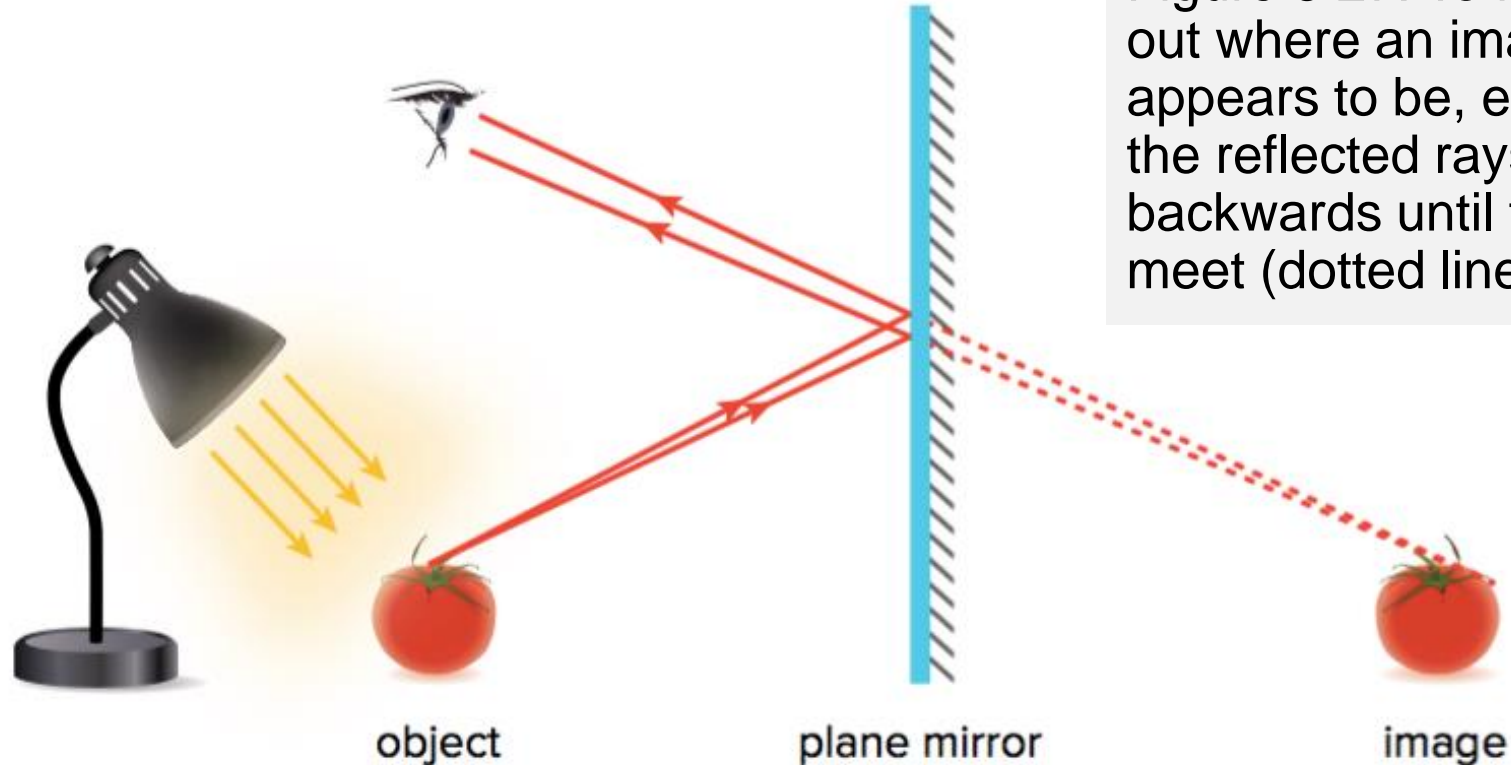

Figure 3.27: To find out where an image appears to be, extend the reflected rays backwards until they meet (dotted line)

Characteristics of Images

- **Location:**
 - Image may be closer to or farther from the mirror than the object.
 - Object may also be the same distance from the mirror as the object.
- **Orientation:**
 - Image be up upright or inverted (upside-down)
- **Size:**
 - Image may be the same size as, larger than, or smaller than the object
- **Type:**
 - Image may be real or virtual

Virtual Image

Virtual image:

- Not a real image
- Formed when extended rays (not reflected rays) meet
- Located behind the mirror

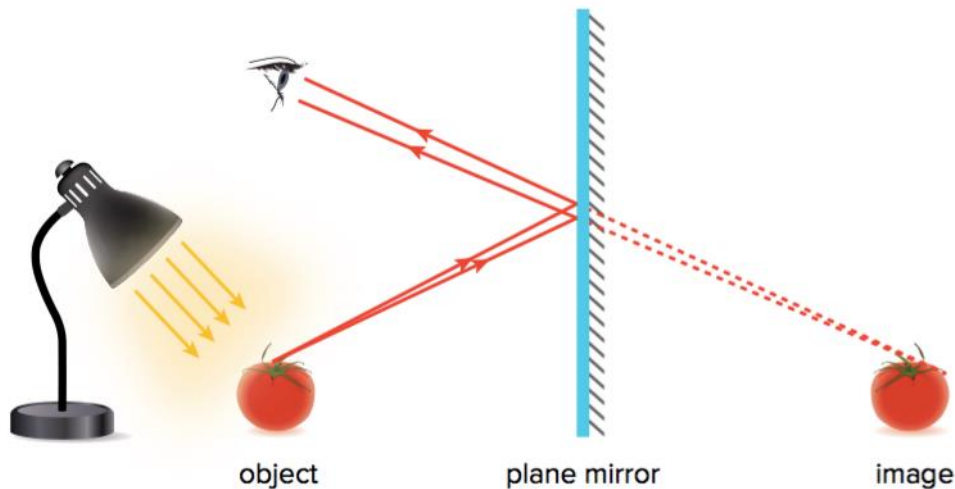

Figure 3.27: No light rays are going to or coming from the image behind the mirror. Light rays only appear to be coming from the image.

- Only extended rays meet
- Brain imagines that an image forms behind the mirror

Real Image

Real image:

- Formed when reflected rays (not extended rays) meet
- Located in front of the mirror
- If you place a screen at the position of a real image, the rays will meet at the screen and form an image
 - Example: an image on a movie screen is a real image

Characteristics of Images in Plane Mirrors

- Same size as the object
- Same distance from the mirror as the object
- Upright
- Virtual image
- Image is nearly identical to the object but is reversed
- Direction of reversal depends on the position of the object and the mirror



Figure 3.28: This image in a plane mirror appears reversed.

Discussion Questions

- What is meant when the image is said to be behind the mirror? What do you call this type of image?



Concept 3: Light reflected by curved mirrors behaves in unique ways.

- Curved mirrors:
 - Do not produce images that are identical to the object
 - What properties of the image in Sky Mirror are different from those in plane mirrors?



Figure 3.29: Sky Mirror by Anish Kapoor (Nottingham, UK)

Curved Mirrors

- How is the image in Cloud Gate similar to the one in Sky Mirror? How is it different?



Figure 3.30: Cloud Gate by Anish Kapoor (Chicago, USA)

Concave and Convex: Two Types of Curved Mirrors

- **Concave mirror:** A mirror with a reflective surface that curves inward (Sky Mirror)
- **Convex mirror:** A mirror with a reflecting surface that curves outward (Cloud Gate)



Images in Concave Mirrors

- Incoming parallel light rays come together (converge) at a single point (focal point)
- Images formed by concave mirror have different characteristics
 - Depend on where it is located compared to surface of mirror and the focal point
 - Images are misshapen around the edges of the mirror

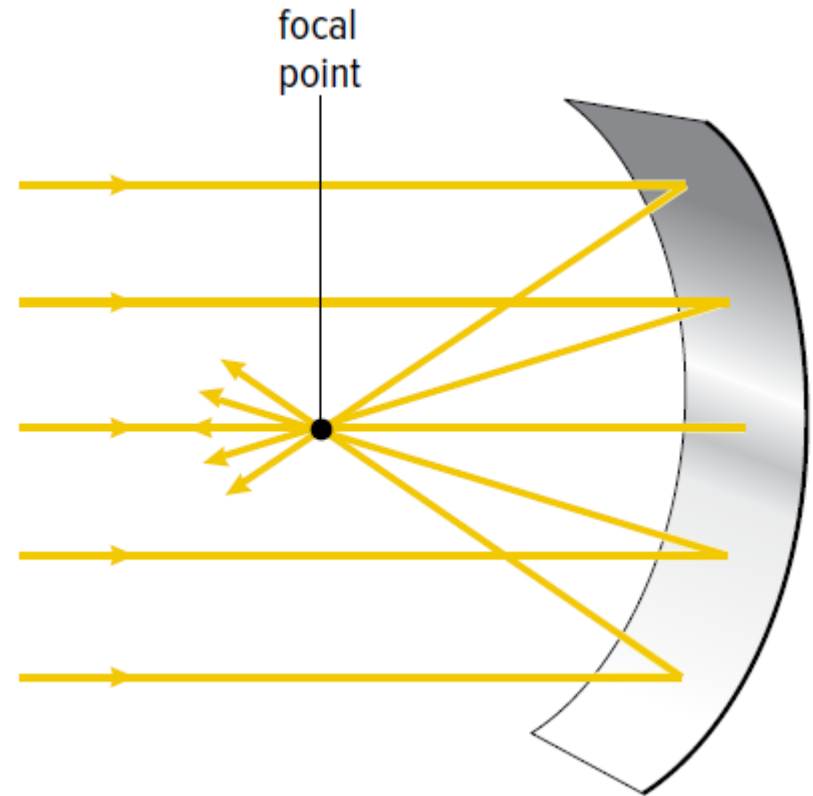

Figure 3.31: Incoming parallel light rays converge when they reflect off a concave mirror.

Characteristics of Images in Concave Mirrors: Object located far from focal point

- Object located far from the focal point
 - Object is reflected to produce a smaller, inverted image
 - Reflected rays meet: image is real
 - Image is closer to the mirror than the object

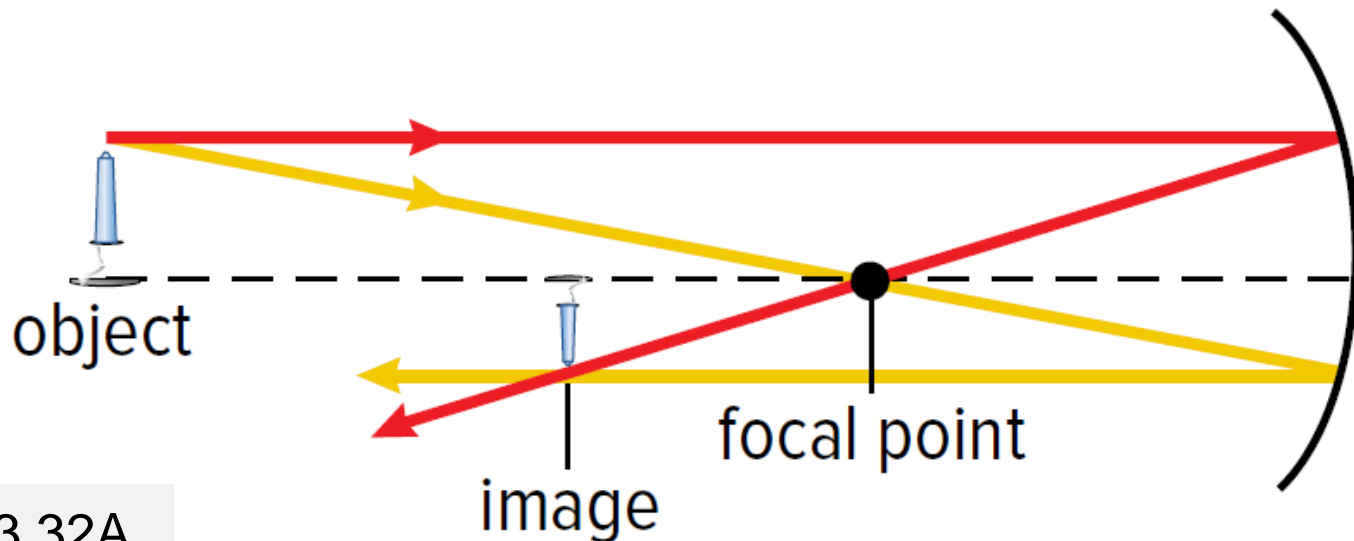

Figure 3.32A

Characteristics of Images in Concave Mirrors: Object located closer to focal point

- Object located closer to the focal point, but is not between the focal point and concave mirror
 - Object is reflected to produce a larger, inverted image
 - Reflected rays meet: image is real
 - Image is farther from the mirror than the object

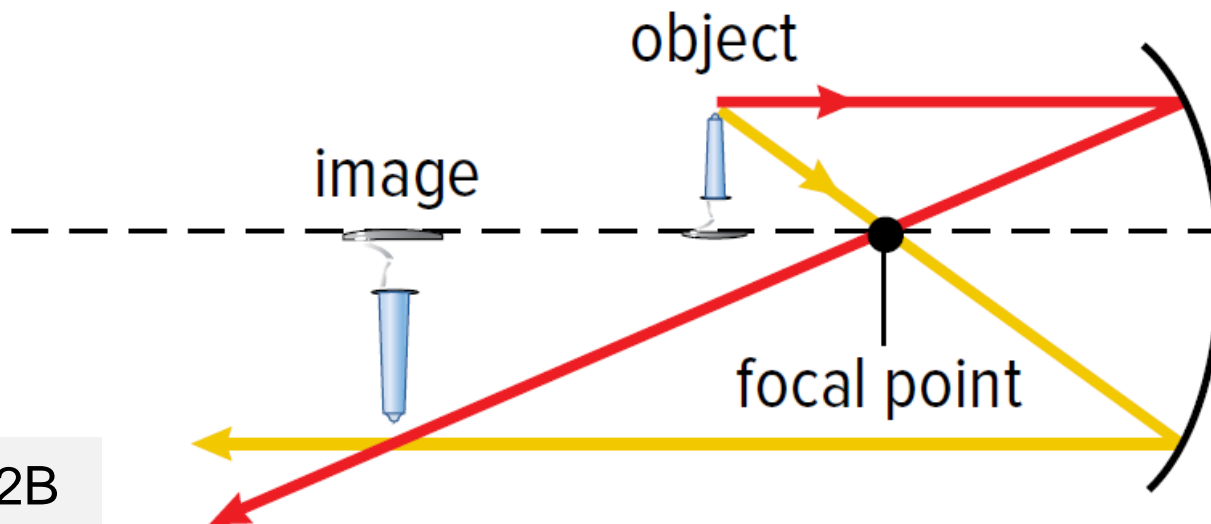

Figure 3.32B

Characteristics of Images in Concave Mirrors: Object located between focal point and concave mirror

- Object located between focal point and concave mirror
 - Object is reflected to produce a larger, upright image
 - Reflected rays do not meet (need to extend them in the opposite direction): image is virtual
 - Image is farther from the mirror than the object

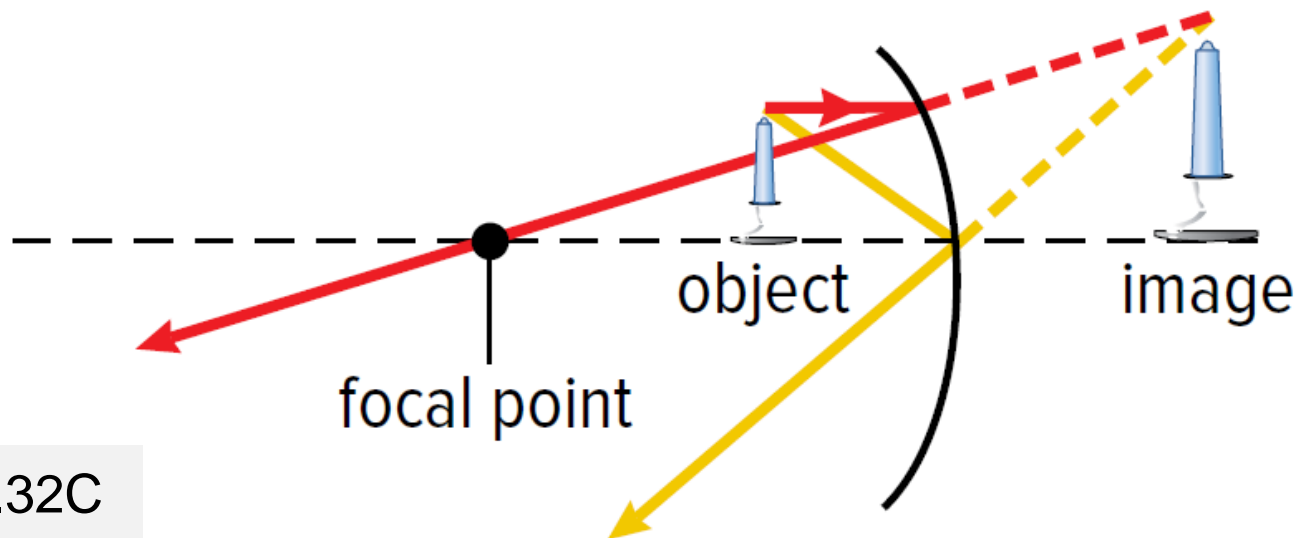

Figure 3.32C

Images in Convex Mirrors

- Incoming parallel light rays spread apart in different directions (diverge) after they are reflected off the mirror
- Extending the diverging rays behind the mirror shows that they meet at a focal point
 - The actual rays do not meet
- Image produced is always a virtual image (like plane mirror images)

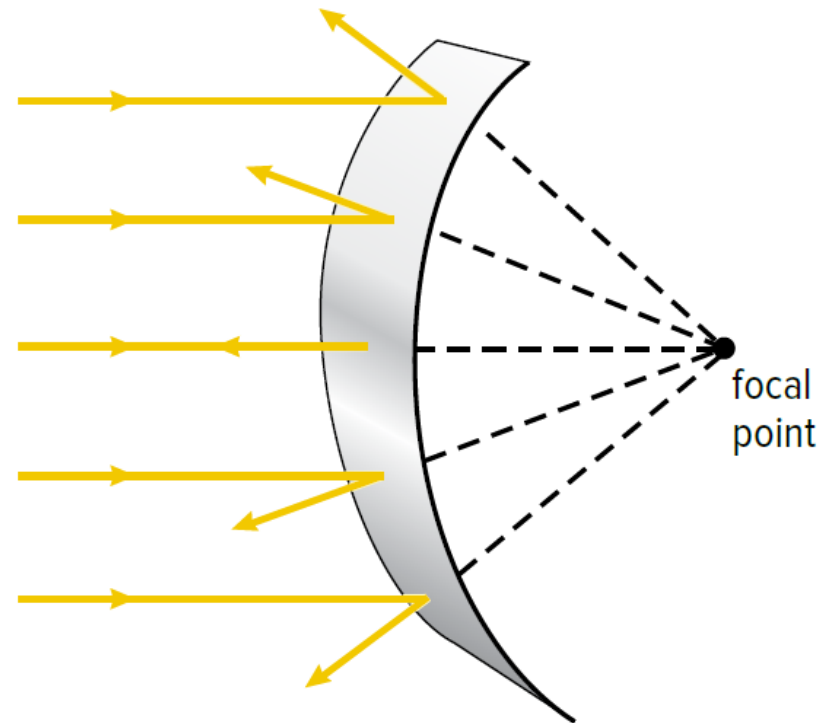

Figure 3.33: Incoming parallel light rays diverge when they reflect off a convex mirror.

Characteristics of Images in Convex Mirrors

- Image is smaller than the object
- Image is closer to the mirror than the object
- Image is virtual
- Image is upright

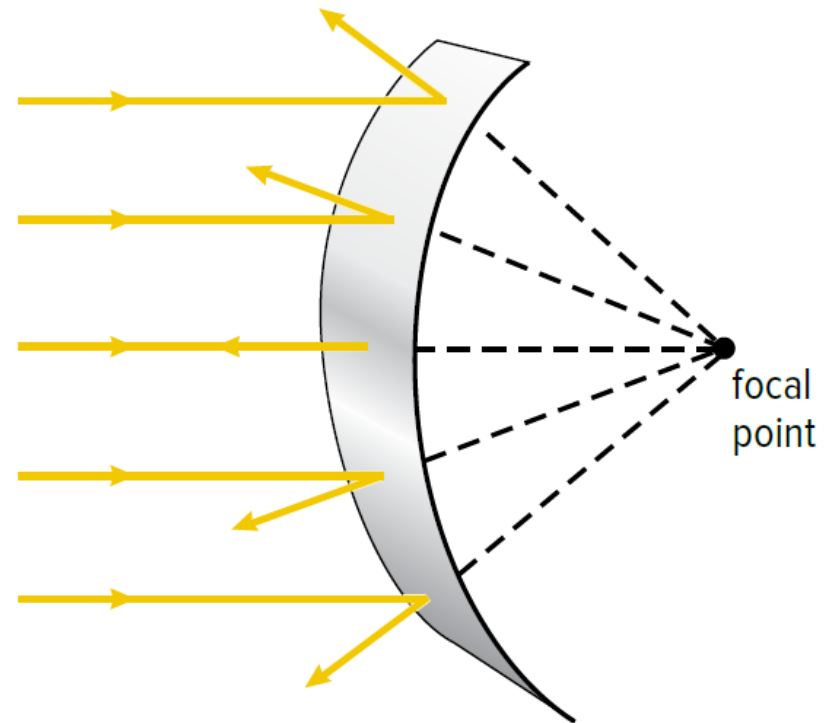

Figure 3.33: Incoming parallel light rays diverge when they reflect off a convex mirror.

Characteristics of Images in Convex Mirrors

- More objects can be seen in a convex mirror than in a plane mirror
 - Convex mirrors reflect light from a large incoming area
- Images are distorted, especially at the edges

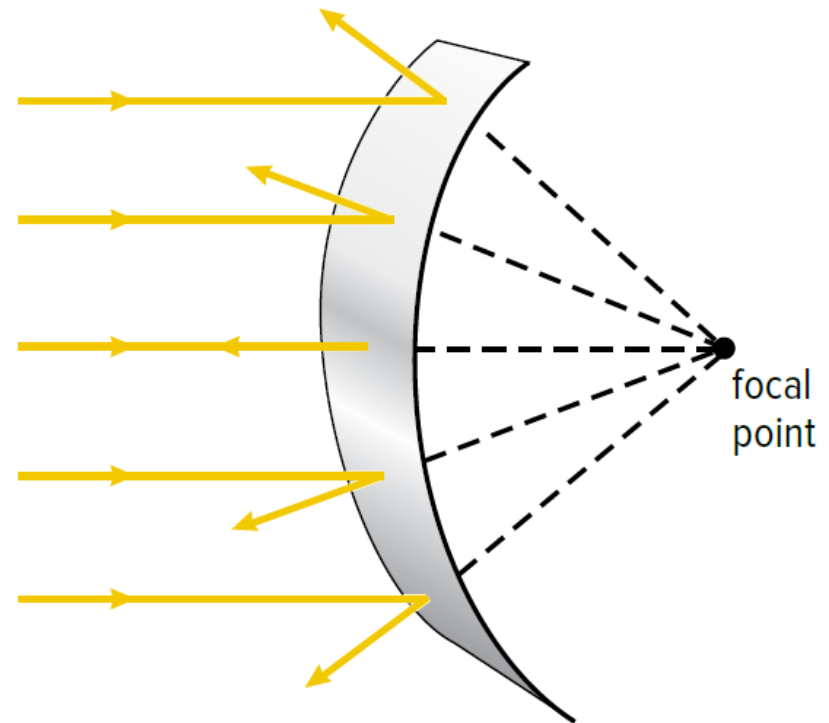

Figure 3.33: Incoming parallel light rays diverge when they reflect off a convex mirror.

Discussion Questions

- Use a T-chart to compare a convex mirror with a concave mirror.
- Convex mirrors are often used as security mirrors in convenience stores. Explain why.



Concept 4: Many technologies take advantage of light's behaviour when it strikes a reflective surface.

Curved Reflective Surfaces

- Concave mirrors: used to concentrate light
 - Light source is located exactly at focal point, the rays that strike the mirror are parallel to each other
 - Produces intense beam of light
 - Used in car headlights, flashlights



Car headlights are composed of concave mirrors.

Curved Reflective Surfaces: Radar

Radar: radio detection and ranging (used to detect aircraft)

- Radar antenna uses a concave reflective surface
 - Radio waves are generated and sent out to the sky
 - Rounded surfaces on airplane are convex reflective surfaces



Curved Reflective Surfaces: Radar

- Some of the surface is perpendicular to the radio waves; will reflect the waves back to antenna
- Antenna's concave surface directs the reflected rays to the detector at the focal point to locate the airplane



Figure 3.34

Plane Reflecting Surfaces

Plane reflecting surfaces help military aircraft avoid radar detection.



Figure 3.35:
Lockheed
F-117
Nighthawk

Plane Reflecting Surfaces

- Angular surfaces on the aircraft are rarely perpendicular to incoming radio waves
 - Very few waves reflect back to the radar antenna

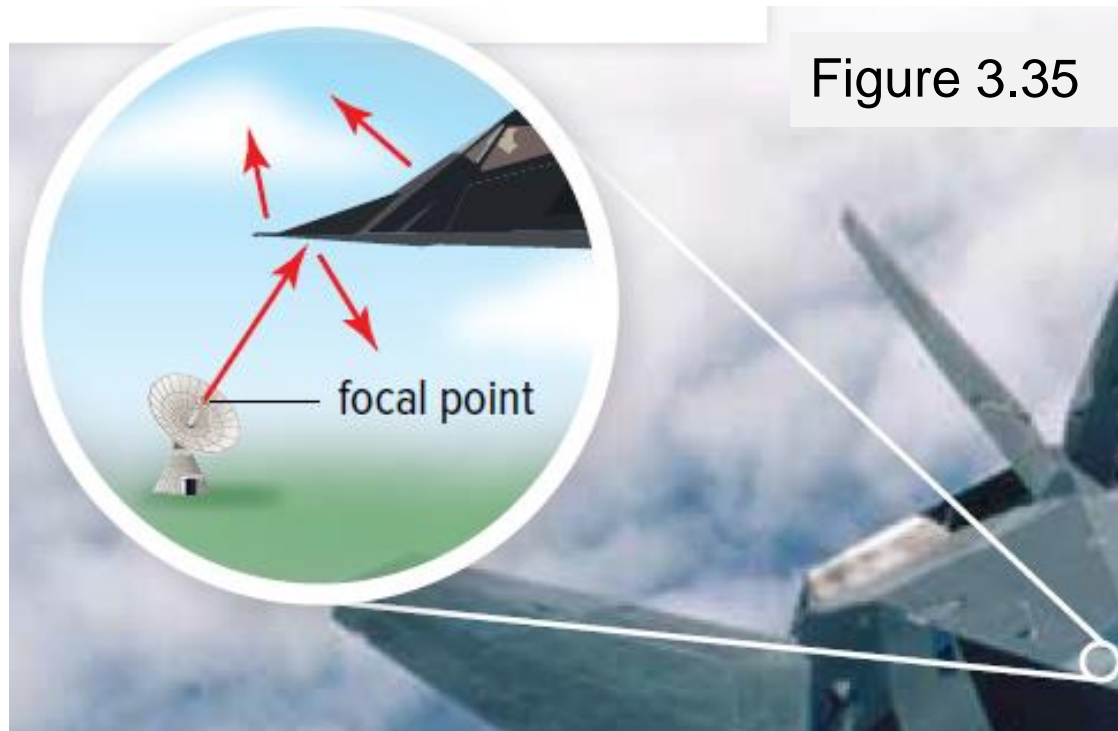

Plane Reflecting Surfaces

- Paint has tiny iron reflecting particles
 - Radio waves reflect back and forth among the iron particles
 - Energy is absorbed by the paint and converted to heat
 - Decreases the number of waves that bounce back to the radar antenna

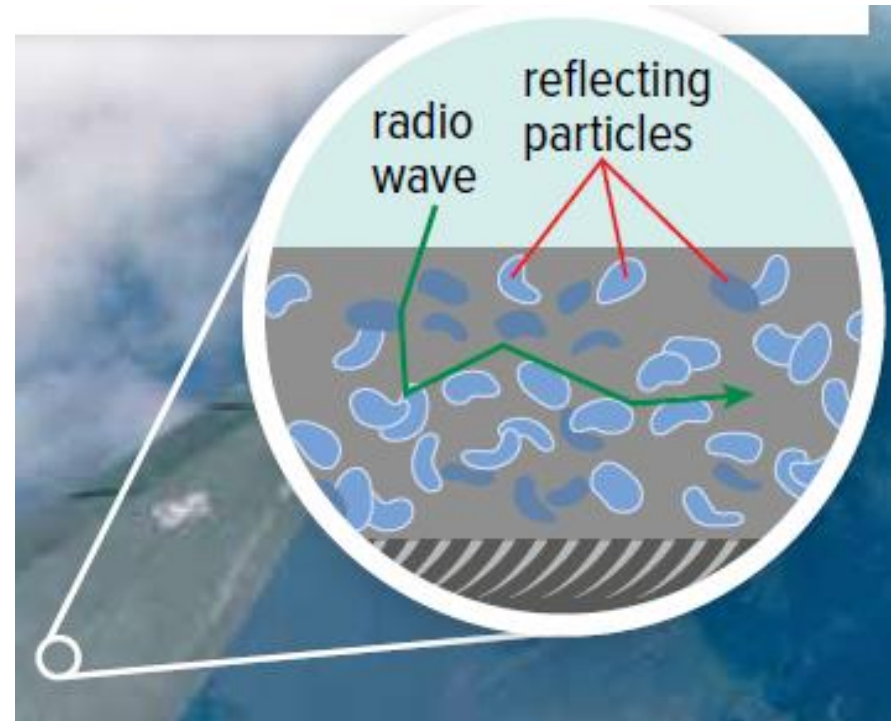
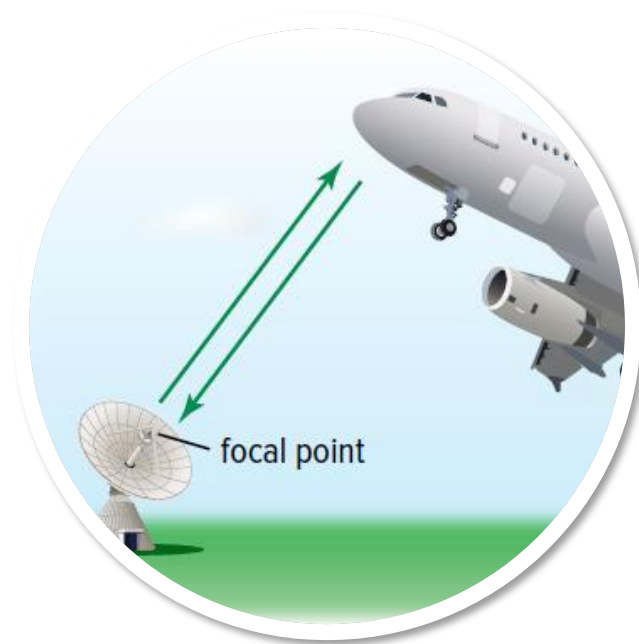

Figure 3.35

Discussion Questions

- Explain how car headlights create an intense beam of light.
- Radio telescopes can detect radio waves from outer space. What shape would a radio telescope most likely be and why?



Summary: How does light behave when it is reflected?

- Light is reflected in predictable patterns.
- Light reflected by a plane mirror produces an image that is nearly identical to the object.
- Light reflected by curved mirrors behaves in unique ways.
- Many technologies take advantage of light's behaviour when it strikes a reflective surface

