

Measuring Accurately and Precisely

SIGNIFICANT FIGURES

Can you draw a straight line that is 3.4 cm long? What about 3.45mm long? Chances are you would have a very difficult time with 3.45mm with a regular ruler. You could measure out 3 mm no problem, and maybe even guess at 3.4. But 3.45 would not be ‘meaningful’, because it would be impossible for you, using a regular ruler, to tell the difference between 3.45mm and 3.46mm.

The precision (or “significant figures”) of a measurement refers to how many meaningful digits a measurement tool can give you. The general rule is to record *to the nearest one-tenth of the smallest division on the measuring device*. (The final digit is estimated by the human eye.)

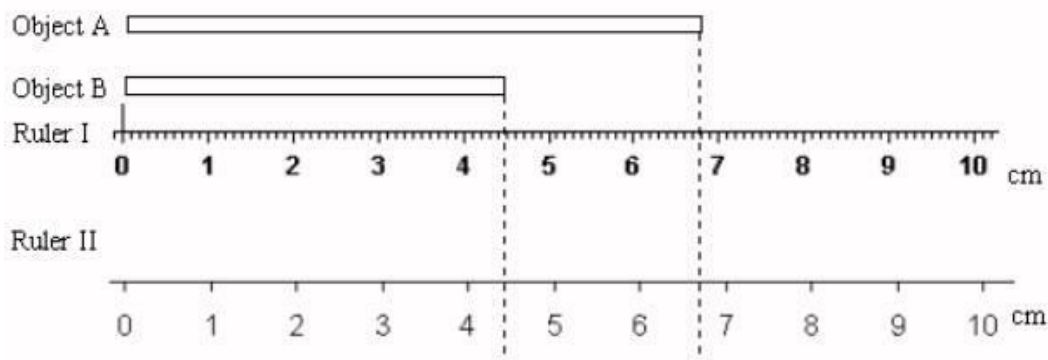

For Ruler I, the smallest division is 0.1cm. One-tenth of 0.1cm is 0.01cm. Thus, measurements using Ruler I should be recorded to the nearest 0.01cm (two decimal places).

For Ruler II, the smallest division is 1cm. One-tenth of 1cm is 0.1cm. Thus, measurements using Ruler II should be recorded to 0.1cm (one decimal place).

1. Record the length of Object A (remember units!), using:
 - a) Ruler I: _____
 - b) Ruler II: _____
2. Record the length of Object B (remember units!), using:
 - c) Ruler I: _____
 - d) Ruler II: _____



- a. What is the smallest division on this ruler? _____
- b. How should measurements using this ruler be recorded? To _____ decimal places
- c. Estimate the length of the arrow. _____

Note: Significant figures are important for any kind of measurement where there is room for human error (e.g. standard thermometers, graduated cylinders, rulers). For digital measurements (e.g. digital scale, digital thermometer), the significant figures are built-in and you would simply record what was on the read-out.

Optional: Read more about significant figures at <http://chemistry.bd.psu.edu/jircitano/sigfigs.html> . Want practice? Ask Ms. Au for a worksheet.

MEASURING TEMPERATURE

1. Why do thermometers need to be handled carefully?
2. a) Suppose you are working at location "A". Draw (on the diagram) how a thermometer should be placed on a lab bench when you are not using it.
b) Why would working with a thermometer at "B" be a bad idea?

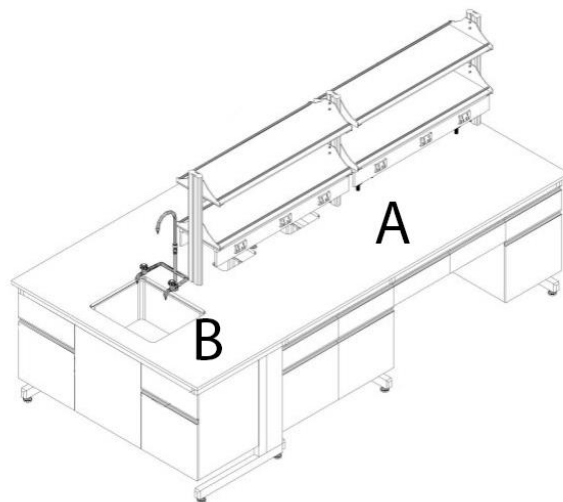

MEASURING MASS

3. Label the following with the names and functions of the equipment. (If you are unsure, ask!)

			
_____	_____	_____	_____
_____	_____	_____	_____

Using a Digital Balance

There are a number of steps to using a digital/electronic balance correctly. Practice weighing out 5.00 grams of the substance provided. Then, if needed, add your own notes and/or diagrams to help you remember what the steps mean.

- 1) Turn on the balance.
- 2) Put a weigh boat onto the balance. Press Tare.
- 3) Use a scoopula to weigh out your substance directly onto the weigh boat.
 - a. Take care not to drop any outside the weigh boat.
 - b. Slow down with your additions when you get closer and closer to your desired amount. If you go over, **do not return the substance to the original bottle**: follow your teacher's instructions to discard the excess.
- 4) To weigh out a different substance, gently brush off anything that is on the surface of the balance, and repeat steps 2 and 3.

Practice Questions

4. What does it mean to tare a balance? Why is this important when weighing things?

5. You are being asked to measure out 10 grams of sugar for your experiment. You follow all the steps and your scale reads 10.00 grams. But after you take off your weigh boat to pour the sugar into the beaker, you see that there are some sugar crystals left on the scale. Will this affect your experiment? If so, how, and what should you do?

6. Why do we never return excess chemicals to the original bottles?

7. The digital balance is not usually used to weigh liquids. Why do you think this is?

MEASURING VOLUMES

Volume is _____ . You are probably familiar with measuring volumes of things at home in your kitchen (e.g. 1 cup of sugar; 150 mL of milk).

- Volume of a solid is measured in _____ or _____.
 - Volume of a liquid is measured in _____ or _____.
 - Note: $1\text{ cm}^3 = 1\text{ mL}$. (Especially important when using the water displacement method to measure the volume of solids.)
8. Measuring the volume of a liquid can be done using laboratory equipment with markings on the sides. Examples are below. Label these pieces of equipment (not drawn to scale).

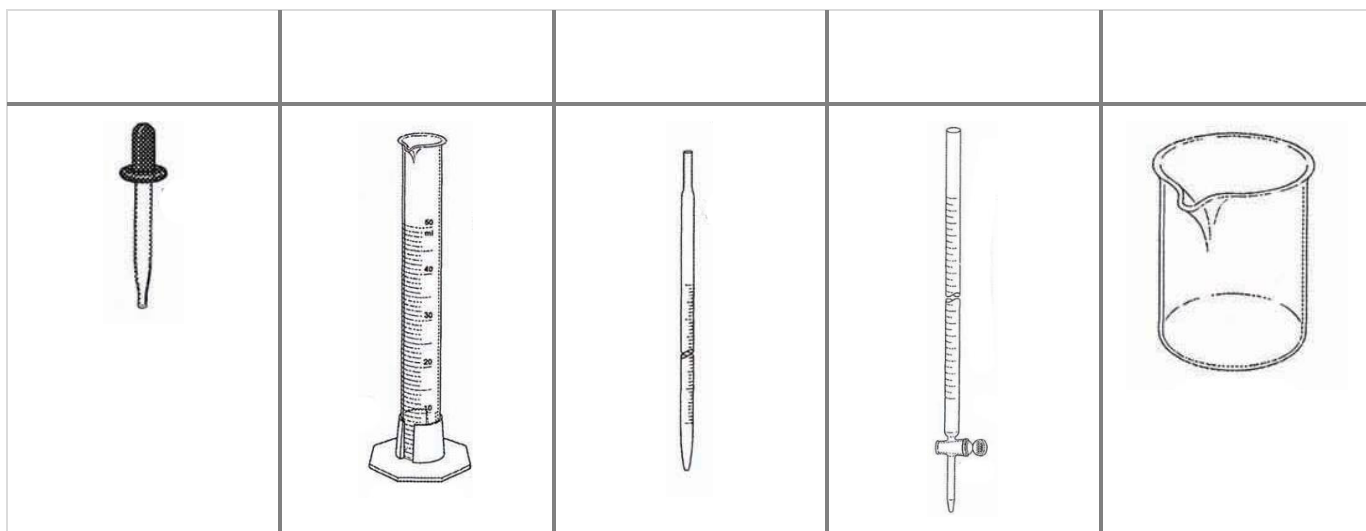

9. Match the following with their functions.

- | | |
|-----------------------|--|
| a. Pipette | Measuring large volumes (e.g. 40 mL, 120 mL) |
| b. Graduated cylinder | Measuring small volumes (e.g. 5 mL, 11 mL) |
| c. Beaker | Measuring volumes very precisely (e.g. 10.3 mL, 34.5 mL) |
| d. Buret | Transferring very small volumes (not very precise) |
| e. Dropper | |

In a science lab, we want to make sure that we are measuring *exactly* the amount that is asked of us. If we don't, experiments may not run the way we expect, or we may waste a lot of (sometimes extremely very expensive!) chemicals.

Sometimes, this can be difficult in _____, burets, and pipettes. In narrow tubes, liquids will form a **meniscus**: the curved upper surface of the liquid. A meniscus forms because of attraction between molecules (when this happens between water molecules, this is referred to as water tension.)

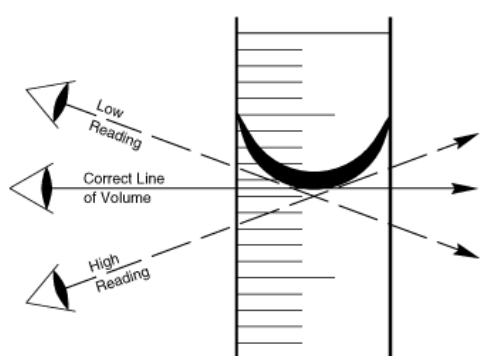

To accurately measure volumes, you must:

- 1) Make sure your eye is level with the liquid level.
- 2) Read the volume that lines up with the bottom of the meniscus.
- 3) Record your volume accurately: there should be one estimated digit.

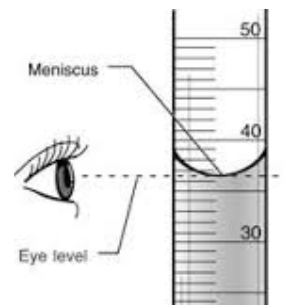

A graduated cylinder with 36.5 mL of water. Make sure your eyes are lined up with the level of the liquid when recording.

Practice Questions

10. Record the volumes in these graduated cylinders. Units are in mL.

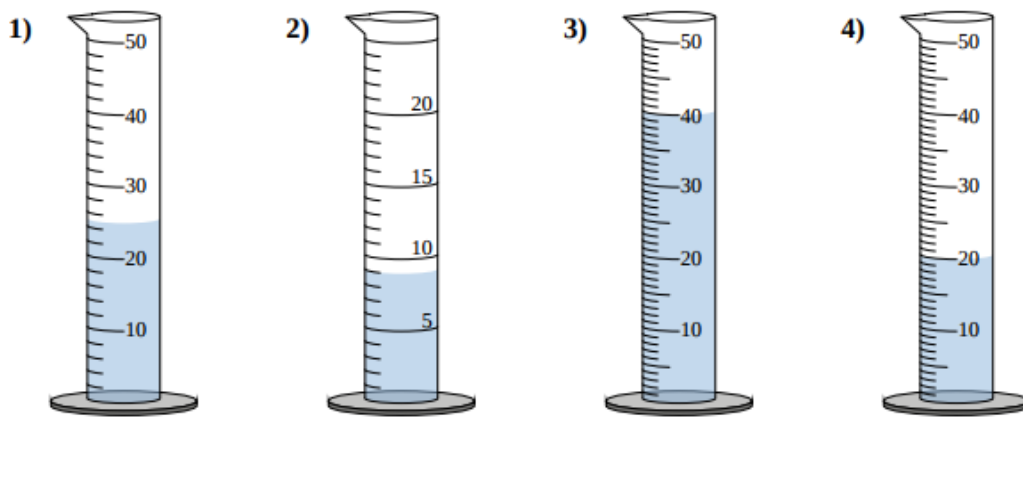

11. Using one of the graduated cylinders available, practice precisely measuring out 20.0mL of tap water.

Water Displacement Method for Solids

The volume of solids can be calculated (using math formulas) or measured. Here, we will focus on measurement using the water displacement method, which is most useful for irregularly shaped solids but can be used for liquids too.

- 1) Select a container (e.g. beaker, graduated cylinder) the object will fit into.
- 2) Pour _____ into the empty container until it is about _____ full.
- 3) Record the volume of water in the container.
- 4) Carefully place the object into the container, and make sure it is fully submerged.
- 5) Record the new volume of the water plus the object.
- 6) Calculate the volume of the solid using the formula:

- 7) Record the volume with proper units. Remember: $1\text{mL}=1\text{cm}^3$. _____ is used for liquids, and _____ for solids.

12. Practice measuring the volumes of the provided solids, using the water displacement method. Remember to clean up each station after you are done (wipe up spilled water with paper towel).

Station	Description of Object	Volume (with units!)

13. Why is it important that the object be fully submerged before you record the total volume (step 4)?

14. Draw diagrams to illustrate each of the steps in determining the volume of a solid. Use the back of the page if necessary.